

DOME PRESSURE REGULATOR ADR 75 for acetylene



High performance pressure regulator, designed to TRGS 407 and type-approved by BAM in accordance with DIN EN ISO 7291 to regulate high flows at acetylene cylinder manifolds or bundles.

Benefits

- extremely low pressure drop (Δp) from static to dynamic conditions (outlet pressure close to 1.5 bar) for heat treatment processes
- 75 Nm³/h flow capacity
- extremely stable outlet pressure independent of inlet pressure and flow for example when using acetylene in heat treatment plants
- integrated pilot pressure regulator with pressure gauge and outlet pressure gauge
- own-medium controlled enabling autonomous operation (no separate gas supply required)
- enables maximum emptying of bundle and trailer systems

Operation / Usage

The ADR 75 for acetylene is used to reduce high pressure to working pressure in acetylene supply systems as required in EN 14114.

Given the high regulating accuracy and flow specifications, it is suitable for all applications needing as a high a dynamic pressure as possible.

Function

The ADR 75 consists of a pilot pressure regulator in combination with a dome loaded pressure regulator.

The required downstream pressure by the pilot pressure regulator to a maximum of 1.5 bar (2.5 bar available on request).

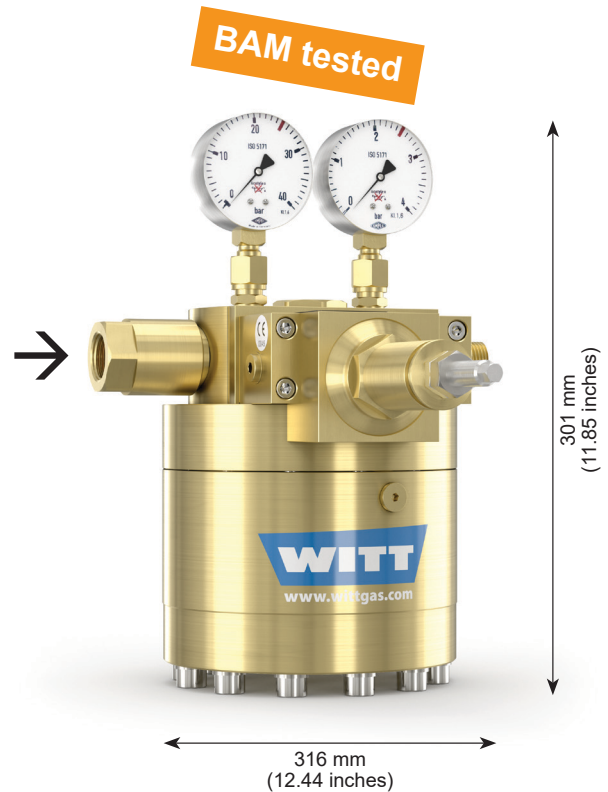

Maintenance

It is recommended that a leak check to atmosphere at regular intervals be conducted. Repairs are only to be carried out by the manufacturer.

Approvals

Company certified according to ISO 9001 and PED 2014/68/EU Module H

CE-marked according to:
- PED 2014/68/EU

Available upon request

Bracket for wall mounting

	Pressure regulator Dome loaded pressure regulator
Type	pneumatic pre-stressed (own-medium controlled)
Gases	acetylene
max. inlet pressure	25 bar, Tested for acetylene decomposition according to DIN EN ISO 15615 BAM Report AZ 23015915
Outlet pressure	0.5 to 1.5 bar 0.5 to 2.0 bar - special version 0.5 to 2.5 bar - special version
Nominal gas flow capacity	75 Nm ³ /h
Inlet	G 3/4 female thread DIN EN ISO 228-1
Filter	stainless steel, filter mesh 100 μ m
Outlet	G 1 female thread DIN EN ISO 228-1
Materials	brass, stainless steel, elastomer
Weight	approx. 24 kg

DOME PRESSURE REGULATOR ADR 75 for acetylene

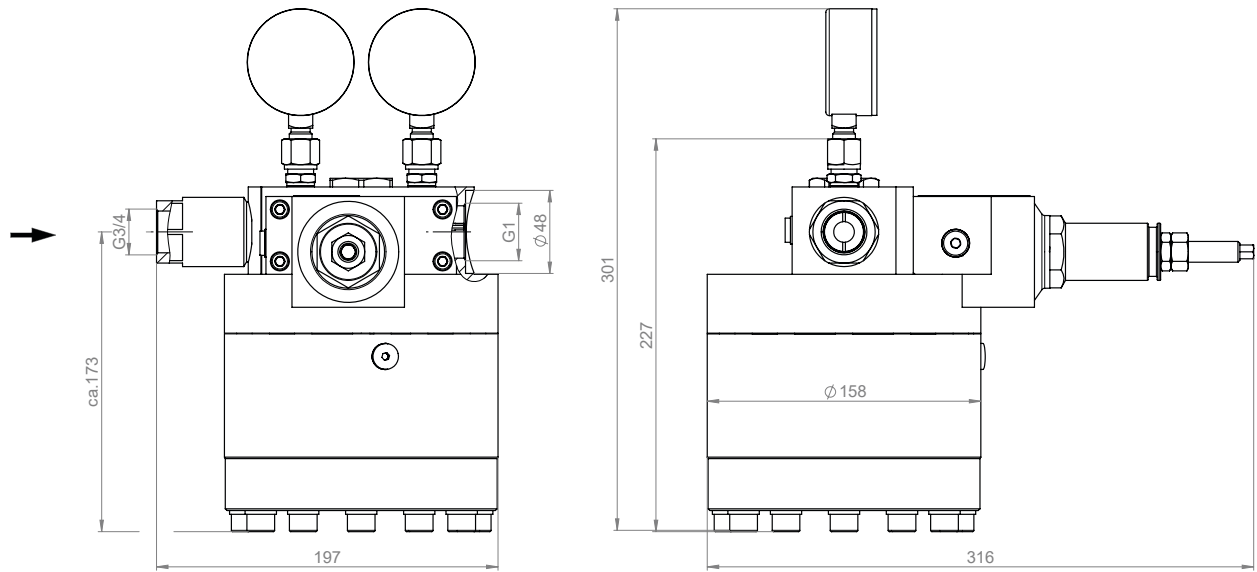

Dimensions in mm

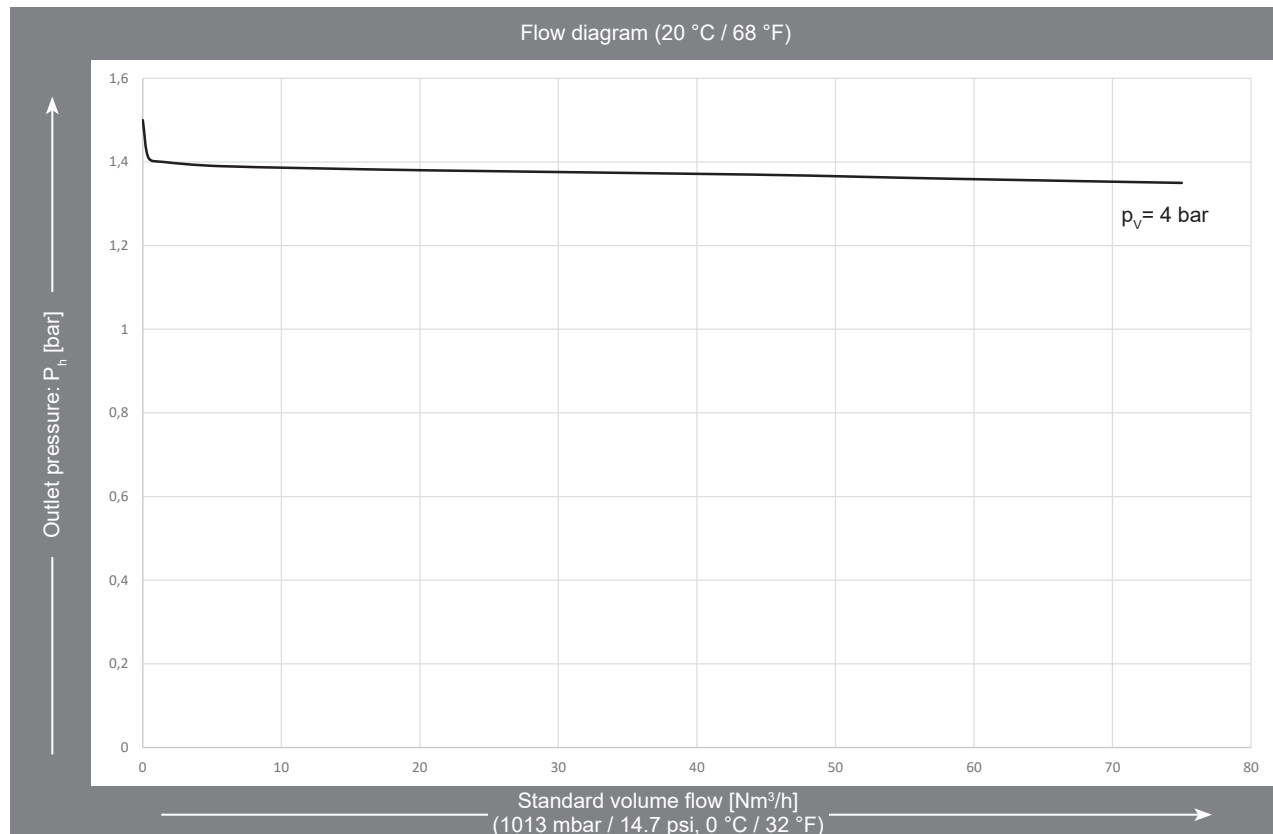

DR8 USA - B01/31 subject to change